

DIMENSIONS

In [mm]

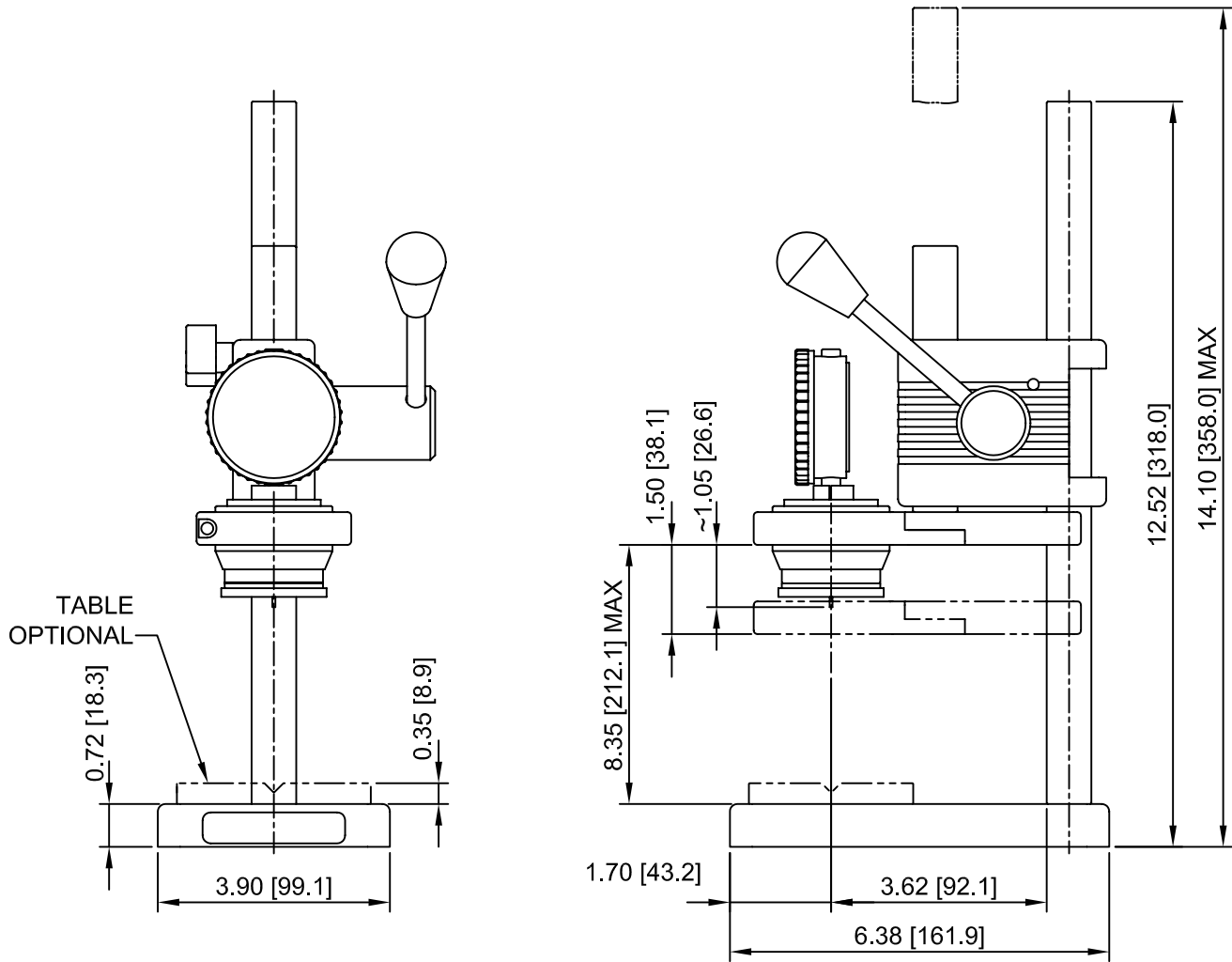

CHECK•LINE® PRECISION QUALITY CONTROL INSTRUMENTS

Electromatic Equipment Co., Inc.
 600 Oakland Ave.
 Cedarhurst, N Y 11516 —USA

Tel: (800) 645-4330 (USA & Canada)
Tel: (516) 295-4300
Fax: (516) 295-4399

Email: info@checkline.com
Website: www.checkline.com

FOR ADDITIONAL INFORMATION OR TO PLACE AN ORDER CALL TOLL FREE 1-800-645-4330